

# luna



LUNA | MODERNO









SOLUZIONI ARREDATIVE DINAMICHE,  
CHE RISPECCHIANO  
LO STILE MODERNO DEL MODELLO LUNA,  
PENSATE PER INCONTRARE NUOVI MODI DI  
VIVERE LO SPAZIO CUCINA.

LA PRESA INTEGRATA NELL'ANTA FORMA  
UN DISEGNO MODULABILE CHE  
CARATTERIZZA I FRONTALI DELLA CUCINA  
CON ELEGANZA.

LE NUMEROSE NUANCE NEUTRE DELLA  
COLLEZIONE TROVANO FORMA IN GRANDI  
CAMPITURE CHE SI AFFIANCANO A SUPERFICI  
PREGIATE IN LEGNO IMPIALLACCIATO.

DYNAMIC FURNISHING SOLUTIONS THAT  
REFLECT THE MODERN STYLE OF THE  
LUNA MODEL, DESIGNED TO CREATE  
NEW WAYS OF EXPERIENCING THE  
KITCHEN AREA.

THE HANDLE INTEGRATED INTO THE  
DOOR FORMS A MODULAR DESIGN  
THAT ELEGANTLY CHARACTERISES THE  
KITCHEN'S FRONT PANELS.

THE NUMEROUS NEUTRAL NUANCES IN  
THE COLLECTION FIND FORM IN LARGE  
FIELDS THAT ARE COMBINED WITH  
PRECIOUS SURFACES IN VENEERED WOOD.

PAG. 4 | LUNA 01 | LACCATO LINO + NOCE CANALETTO

PAG. 14 | LUNA 02 | ROVERE GRIGIO TRAFFICO + LACCATO GRIGIO TRAFFICO

PAG. 26 | LUNA 03 | ROVERE MORESCO + LACCATO BIANCO ASSOLUTO

PAG. 36 | LUNA 04 | NOCE CANALETTO + LACCATO BISTRO

PAG. 46 | LUNA 05 | ROVERE CARBON + LACCATO BIANCO ASSOLUTO

PAG. 56 | LUNA 06 | ROVERE LINO + LACCATO LINO

PAG. 66 | LUNA 07 | ROVERE BIANCO + LACCATO GRIGIO PIOMBO

PAG. 78 | LUNA 08 | ROVERE NATUR + LACCATO BIANCO ASSOLUTO

PAG. 88 | LUNA 09 | ROVERE MORESCO + LACCATO FUMO

PAG. 100 | LUNA 10 | ROVERE GRIGIO REALE + LACCATO CENERE

PAG. 112 | FINITURE

PAG. 118 | INFORMAZIONI TECNICHE

## LUNA 01 | LACCATO LINO + NOCE CANALETTO

LA PIÙ CLASSICA DELLE ESSENZE, INTREPRETE PRINCIPALE DI UNA CUCINA MODERNA E TECNOLOGICAMENTE ALL'AVANGUARDIA.

IL NOCE CANALETTO, CALDO NELLE SUE SFUMATURE NATURALI, È ESALTATO DALLA LUMINOSITÀ DEL LINO LACCATO OPACO, CREANDO UN AMBIENTE DI ALTO PROFILO ESTETICO.

CLASSICAL FINISHES, PLAYING THE LEADING ROLE IN A MODERN AND TECHNOLOGICALLY ADVANCED KITCHEN. CANALETTO WALNUT, WITH ITS WARM NATURAL TONES, IS ENHANCED BY THE BRIGHTNESS OF THE MATT LACQUERED LINEN, CREATING A ROOM WITH A HIGH AESTHETIC PROFILE.













LUNA 01





IL PIANO SNACK DELLA PENISOLA, IMPIALLACCIATA IN NOCE CANALETTO, HA UNA FORMA ARROTONDATA PENSATA PER DIVENTARE IL CENTRO DELL'ATTIVITÀ DELLA CUCINA.

THE SNACK BAR OF THE PENINSULA UNIT, VENEERED IN CANALETTO WALNUT, HAS A ROUNDED SHAPE DESIGNED TO BECOME THE CENTRE OF WHATEVER IS HAPPENING IN THE KITCHEN.







LA ZONA PRANZO È VALORIZZATA DA TAVOLO E SEDIE COORDINATE NELLE TONALITÀ E DALLE MADIE, NUOVE DAL PUNTO DI VISTA COMPOSITIVO E CARATTERIZZATE DA RAFFINATI DETTAGLI COSTRUTTIVI.

THE EATING AREA IS ENHANCED BY A TABLE AND CHAIRS, COORDINATED WITH THE SHADES AND THE SIDEBOARDS, ALL OF WHICH ARE NEW IN TERMS OF COMPOSITION AND CHARACTERISED BY REFINED CONSTRUCTION DETAILS.















## LUNA 02 | ROVERE GRIGIO TRAFFICO + LACCATO GRIGIO TRAFFICO

SCALATURE DI TONALITÀ E RICERCA ACCURATA DEI MATERIALI PER UNA SOLUZIONE COMPOSITIVA CAPACE DI INTEGRARE FUNZIONALITÀ ED ESTETICA. UN PROGETTO CHE, GRAZIE AGLI SCHIENALI ATTREZZATI, PROPONE UN MODO NUOVO DI VIVERE LA CUCINA CHE NON PREVEDE SPAZI INUTILIZZATI.

NUANCES OF SHADES AND CAREFUL RESEARCH OF MATERIALS FOR A COMPOSITION CAPABLE OF INTEGRATING BOTH FUNCTIONALITY AND AESTHETICS. A DESIGN WHICH, THANKS TO THE ACCESSORISED BACK PANELS, OFFERS A NEW WAY OF EXPERIENCING THE KITCHEN, WITH NO AREA LEFT UNTOUCHED OR UNUSED.















IL RETRO DELLA PENISOLA, SOTTO AL PIANO DI LAVORO DALL'AMPIA SUPERFICIE DI UTILIZZO, OSPITA DUE VANI A GIORNO CHE ALLEGGERISCONO LA COMPOSIZIONE DANDO UN CARATTERE DISTINTIVO.

THE BACK OF THE PENINSULA UNIT, BELOW THE WORKTOP WITH THE LARGE USEFUL SURFACE AREA, HOUSES TWO OPEN COMPARTMENTS THAT LIGHTEN THE COMPOSITION GIVING IT A DISTINCTIVE CHARACTER.





















IL BLOCCO DELLE COLONNE E' ORGANIZZATO PER SFRUTTARE INTELLIGENTEMENTE LO SPAZIO, LASCIANDO AL CENTRO UN PIANO DI LAVORO DI GRANDE PRATICITÀ.

THE TALL UNIT IS ORGANIZED SO AS TO INTELLIGENTLY EXPLOIT THE SPACE, LEAVING A PRACTICAL WORKTOP AT THE CENTRE.



UN LIVING DALLE LINEE LEGGERE MA DI FORTE APPEAL, GRAZIE ALL'ARMONIA DEL ROVERE LACCATO A PORO APERTO GRIGIO TRAFFICO, ABBINATO ALLA STESSA TONALITÀ IN LACCATO OPACO.

A LIVING AREA WITH LIGHT LINES BUT WITH A STRONG APPEAL, THANKS TO THE HARMONY OF THE OPEN PORE LACQUER OAK IN TRAFFIC GREY, COMBINED WITH THE SAME SHADE IN MATT LACQUER.









## LUNA 03 | ROVERE MORESCO + LACCATO BIANCO ASSOLUTO

UNO SCRIGNO, ILLUMINATO DAL BIANCO ASSOLUTO E IMPREZIOSITO DAI VANI A GIORNO CON SCOMPARTI IN VETRO, RACCHIUDE LA ZONA LAVORO DI QUESTA COMPOSIZIONE ARRICCHITA DALL'ELEGANZA DEL ROVERE MORESCO.

AN ENCASED AREA, ILLUMINATED BY THE ABSOLUTE WHITE WHICH IS EMBELLISHED BY THE OPEN COMPARTMENTS WITH GLASS DIVIDERS, CONTAINS THE WORK AREA OF THIS COMPOSITION ENRICHED BY THE ELEGANCE OF MOORISH OAK.

















UNA COMPOSIZIONE CARATTERIZZATA  
DA ARMADIATURE CAPACI DI GRANDE  
CONTENIMENTO IN PERFETTO  
EQUILIBRIO CON I VANI A GIORNO CHE  
SEGUONO LA CONFORMAZIONE  
DELL'ISOLA, DONANDOLE UNA VALENZA  
ESTETICA SENZA PARAGONI.

A COMPOSITION CHARACTERISED BY  
CUPBOARDS WITH AMPLE STORAGE  
POSSIBILITIES, PERFECTLY BALANCED  
WITH THE OPEN COMPARTMENTS THAT  
FOLLOW THE SHAPE OF THE ISLAND,  
GIVING IT AN UNPARALLELED AESTHETIC  
VALUE.



LA ZONA PRANZO OSPITA UNA  
COMPOSIZIONE PENSILE ESSENZIALE  
CHE GIOCA SU CONTRASTI CREATI TRA  
ANTE CHIUSE E MODULI A GIORNO E TRA  
IL BIANCO ASSOLUTO ED IL FUMO.

THE EATING AREA INCLUDES A  
MINIMALIST WALL UNIT WHICH  
PLAYS ON THE CONTRASTS BETWEEN  
THE CLOSED DOORS AND THE OPEN  
MODULES, AND BETWEEN THE ABSOLUTE  
WHITE AND SMOKE GREY.

















## LUNA 04 | NOCE CANALETTO + LACCATO BISTRO

L'ELEGANZA CARATTERIZZA OGNI ASPETTO DI QUESTA COMPOSIZIONE. IL NOCE CANALETTO SI ABBINA PERFETTAMENTE AI DETTAGLI IN RAME DEGLI ELETTRODOMESTICI E DELLA CAPPA A SOSPENSIONE. LE SEDIE E GLI SGABELLI RIPRENDONO LE FINITURE DELLA CUCINA E DEI COMPLEMENTI E LA GRANDE PARETE ATTREZZATA IMPREZIOSISCE L'ESTETICA DELLA COMPOSIZIONE.

ELEGANCE DEFINES EACH ASPECT OF THIS COMPOSITION. CANALETTO WALNUT PERFECTLY MATCHES THE COPPER DETAILS EMBEDDED IN THE APPLIANCES AND IN THE SUSPENDED HOOD. THE CHAIRS AND THE STOOLS REPRODUCE THE FINISHES OF THE KITCHEN AND OF ITS ACCESSORIES, WHILE THE BIG WALL UNIT ADDS AESTHETIC PERSONALITY TO THE COMPOSITION.





























THE LIGHT OF VENICE  
THE LIGHT OF LONDON

THE LIGHT OF VENICE  
THE LIGHT OF LONDON

THE LIGHT OF VENICE  
THE LIGHT OF LONDON  
THE LIGHT OF BEIJING

SALAD FOR DINNER  
THE LIGHT OF BEIJING



IN UN GIOCO DI PIENI E VUOTI PRENDE FORMA LA ZONA GIORNO, DOVE LE ANTE A TELAIO E LE MENSOLE IN NOCE CANALETTO EMERGONO DALLA BOISERIE IN LACCATO BISTRO.

A PLAY OF FILLED AND EMPTY SPACES DEFINES THE LIVING AREA, WHERE FRAME DOORS AND CANALETTO WALNUT SHELVES EMERGE FROM THE LACQUERED BISTRE BOISERIE.









## LUNA 05 | ROVERE CARBON + LACCATO BIANCO ASSOLUTO

FORTI CONTRASTI PER QUESTA COMPOSIZIONE DOVE IL ROVERE CARBON SI ACCOSTA AL LACCATO BIANCO ASSOLUTO. UN ALTERNARSI DI MENSOLE, VANI A GIORNO E COMPLEMENTI IN METALLO COMPLETANO L'AMBIENTE.

STRONG CONTRASTS MARK THIS COMPOSITION, WHERE CARBON OAK MATCHES WITH ABSOLUTE WHITE LACQUERED. AN ALTERNATION OF SHELVES, OPEN UNITS AND METAL ACCESSORIES COMPLETE THE ENVIRONMENT.













LUNA 05

JUICY DRINKS  
SALAD & DINNER

SALAD & DINNER

JUICY DRINKS

JUICY DRINKS



























## LUNA 06 | ROVERE LINO + LACCATO LINO

UNA CUCINA AMPIA E LUMINOSA CHE UNISCE ALLA LINEARITÀ DELLA FORMA IL CONTRASTO TRA LA FINITURA CHIARA E DELICATA DELLE ANTE CON QUELLA MATERICA DEL PIANO IN FORTE SPESSORE.

A SPACIOUS AND BRIGHT KITCHEN, WHICH COMBINES LINEAR SHAPES WITH CONTRAST BETWEEN THE SOFT AND DELICATE FINISH OF CABINET DOORS AND THE MATERIAL ONE OF THE EXTRA THICK TOP.























LA LIBRERIA A PARETE INCORNICIA  
LE COLONNE, PER UNA SOLUZIONE  
FUNZIONALE CHE RECUPERA TUTTO LO  
SPAZIO A DISPOSIZIONE.

THE WALL BOOKCASE FRAMES THE  
COLUMNS, FOR A FUNCTIONAL  
SOLUTION WHICH SAVES ALL THE  
AVAILABLE SPACE.

















## LUNA 07 | ROVERE BIANCO + LACCATO GRIGIO PIOMBO

UNA SOLUZIONE CHE OFFRE UN AMPIO CONTENIMENTO CON LA LEGGEREZZA CROMATICA DELLE ANTE IN ROVERE BIANCO, IN CONTRASTO ALLA FASCIA DEI PENSILI IN GRIGIO PIOMBO. PICCOLI TOCCHI CARATTERIZZATI DAGLI ELEMENTI A GIORNO E DALLA LIBRERIA CREANO UNA VESTE UNICA ALLA CUCINA.

A SOLUTION THAT OFFERS AMPLE STORAGE WITH THE LIGHT TONES OF THE WHITE OAK DOORS, IN CONTRAST TO THE RANGE OF WALL UNITS IN LEAD GREY, SMALL TOUCHES CHARACTERISED BY THE OPEN ELEMENTS AND THE BOOKCASE WHICH COMBINE TO CREATE A UNIQUE LOOK FOR THE KITCHEN.



















IL PIANO DELLA CUCINA SI ALLUNGA  
IN DUE DIREZIONI, A DIVENTARE UNA  
PENISOLA CHE OSPITA LA ZONA  
COTTURA E UNA PRATICA ZONA SNACK.

THE KITCHEN TOP EXTENDS IN TWO  
DIRECTIONS, TO BECOME A PENINSULA  
UNIT HOUSING THE COOKING ZONE AND  
A PRACTICAL SNACK AREA.



















LA NUOVA FINITURA MALTA LACCATA  
CON FONDO IN CEMENTO CARATTERIZZA  
LE BASI DELLA SOLUZIONE LIVING CON  
LA SUA MATERICITÀ.

THE NEW LACQUERED MORTAR FINISH  
WITH A CEMENT BASE CHARACTERISES  
THE FOUNDATIONS OF THIS LIVING  
AREA WITH ITS TEXTURED EFFECT.









## LUNA 08 | ROVERE NATUR + LACCATO BIANCO ASSOLUTO

UNA COMPOSIZIONE DAL SAPORE NORDICO, DOVE SI ACCOSTA LA LUMINOSITÀ DEL BIANCO ASSOLUTO ALLA PUREZZA DEL ROVERE NATURALE, PER UN MIX DI MATERIALI CHE CONFERISCE AMPIEZZA ALL'AMBIENTE.

A NORDIC STYLE COMPOSITION, WHERE THE BRIGHTNESS OF ABSOLUTE WHITE MEETS THE PURENESS OF NATURAL OAK, IN A MIX OF DIFFERENT MATERIALS WHICH GIVES SPACIOUSNESS TO THE ROOM.





























LA PARTE TERMINALE DELLA CUCINA SI FONDE AL LIVING E IL TOP SI ALLUNGA SINO A DIVENTARE UN PIANO SNACK PER UNA PERFETTA CONTINUITÀ TRA LE ZONE GIORNO.

THE EXTREMITY OF THE KITCHEN BLENDS WITH THE LIVING AND THE TOP EXTENDS SO AS TO BECOME A SNACK BAR, IN ORDER FOR THE LIVING ROOMS TO BE HARMONIOUSLY INTEGRATED.





LA MADIA SI PRESENTA COME UNO DEGLI ELEMENTI CARATTERIZZANTI DELLA COLLEZIONE. SI COMPLETA ANCH'ESSA CON L'ANTA SAGOMATA CHE NE RAFFORZA L'ESTETICA.

THE CUPBOARD REPRESENTS ONE OF THE DISTINCTIVE FEATURES OF THE COLLECTION. ITS AESTHETIC APPEAL IS STRENGTHENED BY THE SHAPED DOOR.









## LUNA 09 | ROVERE MORESCO + LACCATO FUMO

ERGONOMIA E COMPATTEZZA PER UNA CUCINA A DUE BLOCCHI FUNZIONALI CHE RISPONDONO A TUTTE LE ESIGENZE DI UTILIZZO. L'ISOLA CON ZONA COTTURA DIVENTA UN AMPIO APPOGGIO PER IL PIANO SNACK IN FINITURA ROVERE. CHE È IN PERFETTA COERENZA STILISTICA E CROMATICA CON IL BLOCCO COLONNE E LAVAGGIO.

ERGONOMICS AND COMPACTNESS FOR A KITCHEN WITH TWO FUNCTIONAL BLOCKS THAT MEET ALL YOUR NEEDS. THE ISLAND WITH ITS COOKING ZONE BECOMES A LARGE SUPPORT FOR THE OAK FINISH SNACK BAR, COORDINATING PERFECTLY, BOTH IN TERMS OF STYLE AND COLOUR WITH THE COLUMN AND WASHING BLOCK.



























LA ZONA LAVAGGIO CON VASCA  
INTEGRATA IN PERFETTA SOLUZIONE DI  
CONTINUITÀ DI MATERIALI, PER CHI NON  
VUOLE RINUNCIARE ALLA PULIZIA DELLE  
FORME.

THE WASHING ZONE WITH A BUILT-IN  
SINK PROVIDES THE PERFECT SOLUTION  
OF CONTINUITY OF MATERIALS, FOR  
THOSE WHO DO NOT WANT TO FOREGO  
CLEAN LINES.





















## LUNA 10 | ROVERE GRIGIO REALE + LACCATO CENERE

UN AMBIENTE UNICO COORDINATO NELLE FINITURE CHE INCLUDE CUCINA, DINING E LIVING E DIVISO SOLO DALLA LIBRERIA INTERPARETE CHE FUNGE DA FILTRO TRA LE VARIE AREE.

A UNIQUE SPACE COORDINATED IN FINISHES WHICH INCLUDES KITCHEN, DINING AND LIVING, AND SEPARATED ONLY BY THE BOOKCASE SERVING AS A FILTER BETWEEN THE DIFFERENT AREAS.





























LO SCHIENALE MAGNETOLAB IN VETRO LUMINOSO A LED OFFRE UNA SOLUZIONE DI ALTISSIMA PULIZIA ESTETICA E DAL FORTE IMPATTO VISIVO, CHE ESALTA LA FUNZIONALITÀ E PERSONALIZZAZIONE DI QUESTA ZONA DELLA CUCINA.

THE LED-LIT GLASS MAGNETOLAB PANEL STANDS OUT FOR ITS UTMOST AESTHETIC CLEANLINESS AND FOR ITS STRONG VISUAL IMPACT, PROVIDING A SOLUTION WHICH SUBLIMATES THE FUNCTIONALITY AND THE CUSTOMIZATION OF THIS AREA OF THE KITCHEN.









IL PIANO SNACK IN LEGNO COLLEGA LE BASI ALL'ISOLA CON UNA SOLUZIONE INUSUALE CHE HA IL DOPPIO SCOPO DI PIANO DI LAVORO E ZONA PRANZO.

THE WOODEN SNACK COUNTER JOINS THE BASES WITH THE ISLAND, PROVIDING AN OUT OF CHARACTER SOLUTION WHICH PERFORMS THE DUAL FUNCTION OF WORKTOP AND DINING AREA.















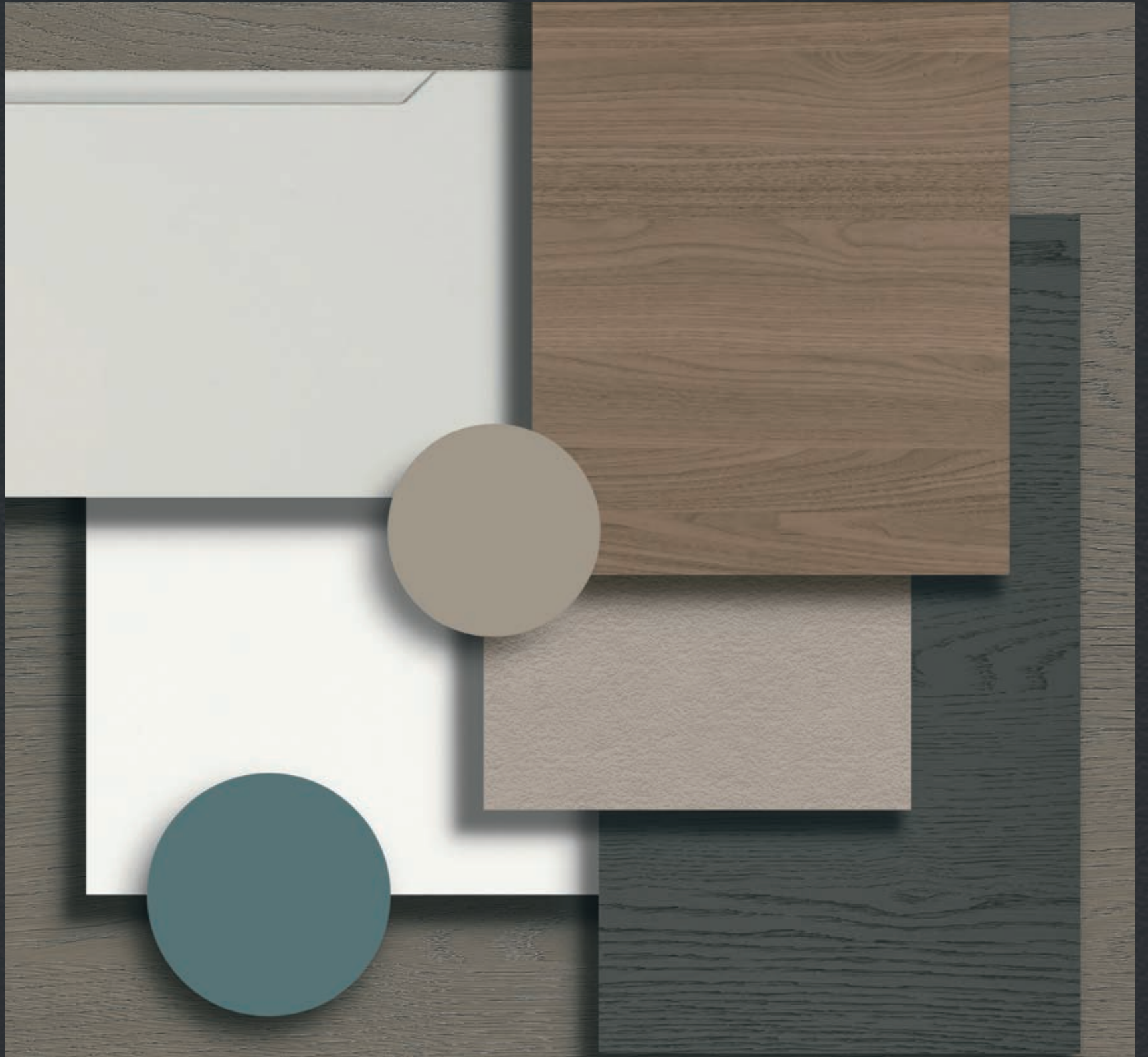



ANTE IMPIALLACCIATE  
ROVERE LACCATO  
A PORO APERTO

VENEERED DOORS IN  
OPEN-PORE LACQUERED OAK



ANTE IMPIALLACCIATE  
ROVERE SPAZZOLATE MATERICHE

VENEERED DOORS IN  
BRUSHED TEXTURED OAK



ANTE VETRO IMPIALLACCIATE

GLASS VENEERED DOORS

NB.: DISPONIBILE IN TUTTE LE FINITURE IMPIALLACCIATE  
NOTE: AVAILABLE IN ALL VENEERED FINISHES





NOCE CANALETTO FIAMMA ORIZZONTALE  
CANALETTO WALNUT HORIZONTAL GRAIN

OPZ. 1331

ANTE IMPIALLACCIATE  
NOCE PORO SEMIAPERTO

WALNUT VENEERED DOORS  
SEMI-OPEN PORE DOORS

OPZ. 1331B

TELAIO  
NOCE CANALETTO  
CON VETRO SATINATO  
CANALETTO WALNUT FRAME  
WITH SATIN GLASS

OPZ. 1331Z

TELAIO  
NOCE CANALETTO  
CON VETRO BRONZO  
CANALETTO WALNUT FRAME  
WITH BRONZE GLASS

ANTE VETRO IMPIALLACCIATE

GLASS VENEERED DOORS

BIANCO  
WHITE

OPZ. LM21

ANTE MALTA LACCATE OPACHE  
CON FONDO CEMENTO

MATT LACQUERED MORTAR FINISH DOORS  
WITH CEMENT SURFACE

CALCE  
CALCE

OPZ. LM23

SABBIA  
SAND

OPZ. LM22

GRIGIO LONDRA  
LONDON GREY

OPZ. LM24

PIOMBO  
PIOMBO

OPZ. LM25



## LACCATO OPACO

MATT LACQUERED

## COLORI FREDDI / COLD COLOURS

BIANCO ASSOLUTO ABSOLUTE WHITE	OPZ. 740S
CENERE ASH	OPZ. 9547
ARGILLA CLAY	OPZ. 9503
GRIGIO BROMO BROMINE GREY	OPZ. 9533
NERO BLACK	OPZ. 7892
BLU NOTTE MIDNIGHT BLUE	OPZ. 8375
BLU FIORDALISO CORNFLOWER BLUE	OPZ. 8377
GRIGIO TRAFFICO GRIGIO TRAFFICO	OPZ. 9511

## COLORI CALDI / WARM COLOURS

BIANCO CALDO WARM WHITE	OPZ. 7401
CANAPA HEMP	OPZ. 8531

GRIGIO KENYA KENYA GREY	OPZ. 9501
CASTORO BEAVER	OPZ. 8907
FUMO SMOKE	OPZ. 9531
GRIGIO PIOMBO LEAD GREY	OPZ. 9537
BISTRO BISTRO	OPZ. 9535
VERDE LICHENE LICHEN GREEN	OPZ. 8463
VERDE POSITANO POSITAN GREEN	OPZ. 8471
GIALLO AMBRA AMBER YELLOW	OPZ. 327S
ROSSO TOSCANO TUSCAN RED	OPZ. 8157
TERRA DI SIENA SIENA EARTH	OPZ. 8161
CRETA CLAY	OPZ. 9515
LINO LINEN	OPZ. 9513
CONCHIGLIA SHELL	OPZ. 7403



## LACCATO LUCIDO SPAZZOLATO

BRUSHED GLOSSY LACQUERED

### COLORI FREDDI / COLD COLOURS

<b>BIANCO ASSOLUTO</b> ABSOLUTE WHITE	OPZ. 740S
<b>CENERE</b> ASH	OPZ. 9548
<b>ARGILLA</b> CLAY	OPZ. 9504
<b>GRIGIO BROMO</b> BROMINE GREY	OPZ. 9534
<b>NERO</b> BLACK	OPZ. 7893
<b>BLU NOTTE</b> MIDNIGHT BLUE	OPZ. 8376
<b>BLU FIORDALISO</b> CORNFLOWER BLUE	OPZ. 8378
<b>GRIGIO TRAFFICO</b> GRIGIO TRAFFICO	OPZ. 9512

### COLORI CALDI / WARM COLOURS

<b>BIANCO CALDO</b> WARM WHITE	OPZ. 7402
<b>CANAPA</b> HEMP	OPZ. 8532

<b>GRIGIO KENYA</b> KENYA GREY	OPZ. 9502
<b>CASTORO</b> BEAVER	OPZ. 8908
<b>FUMO</b> SMOKE	OPZ. 9532
<b>GRIGIO PIOMBO</b> LEAD GREY	OPZ. 9538
<b>BISTRO</b> BISTRO	OPZ. 9536
<b>VERDE LICHENE</b> LICHEN GREEN	OPZ. 8464
<b>VERDE POSITANO</b> POSITAN GREEN	OPZ. 8472
<b>GIALLO AMBRA</b> AMBER YELLOW	OPZ. 328
<b>ROSSO TOSCANO</b> TUSCAN RED	OPZ. 8158
<b>TERRA DI SIENA</b> SIENA EARTH	OPZ. 8162
<b>CRETA</b> CLAY	OPZ. 9516
<b>LINO</b> LINEN	OPZ. 9514
<b>CONCHIGLIA</b> SHELL	OPZ. 7404



## LUNA | INFORMAZIONI TECNICHE







## LUNA | TIPOLOGIE ANTA

MOLTEPLICI TIPOLOGIE DI ANTE SAGOMATE CON PRESA INTEGRATA CHE CONSENTONO DI CREARE DIVERSE COMBINAZIONI STILISTICHE, MOTIVO CARATTERIZZANTE DELLA CUCINA STESSA.

NUMEROUS TYPES OF SHAPED DOORS WITH INTEGRATED GRIP THAT ALLOW FOR DIFFERENT STYLISTIC COMBINATIONS, A DISTINCTIVE FEATURE OF THE KITCHEN ITSELF.

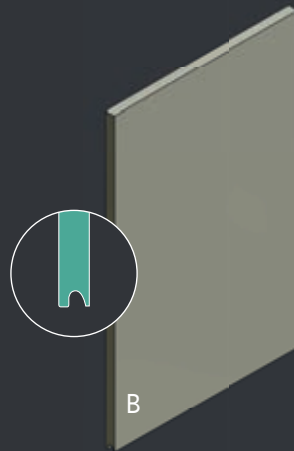

TIPO B  
ANTA PER PENSILI  
CON PRESA ORIZZONTALE

TYPE B  
DOOR FOR WALL UNITS  
WITH HORIZONTAL GRIP

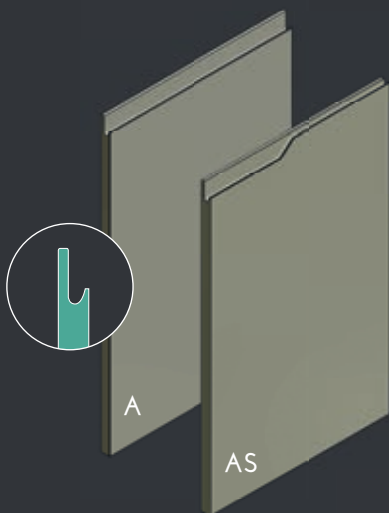

TIPO A - AS  
ANTE PER BASI  
CON PRESA ORIZZONTALE  
CON E SENZA SAGOMATURA

TYPE A - AS  
DOORS FOR BASE UNITS  
WITH HORIZONTAL GRIP  
WITH AND WITHOUT PROFILE

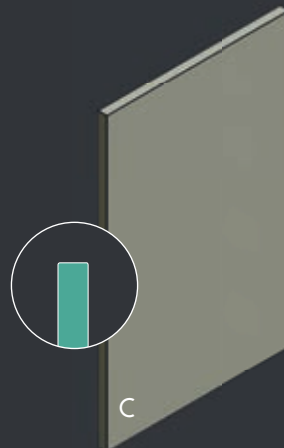

TIPO C  
ANTA SENZA PRESA  
PER BASE TERMINALE A GIORNO

TYPE C  
DOOR WITHOUT GRIP  
FOR OPEN END UNIT

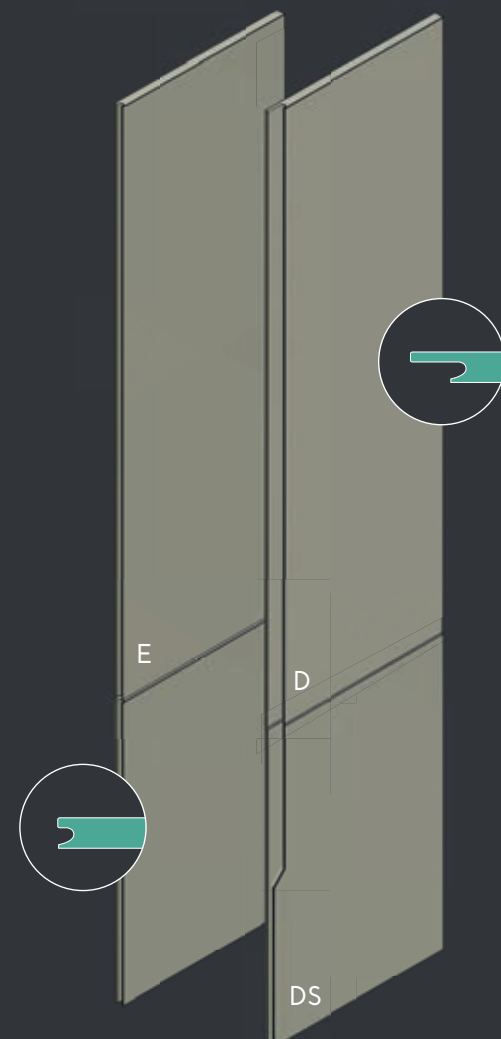

TIPO D - DS - E  
ANTE PER COLONNE  
CON PRESA VERTICALE  
CON E SENZA SAGOMATURA

TYPE D - DS - E  
DOORS FOR COLUMNS  
WITH HORIZONTAL GRIP  
WITH AND WITHOUT PROFILE



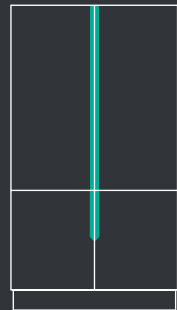
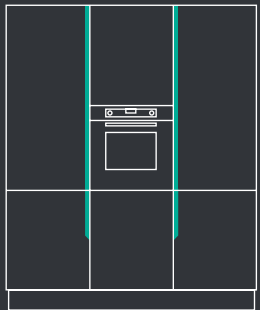
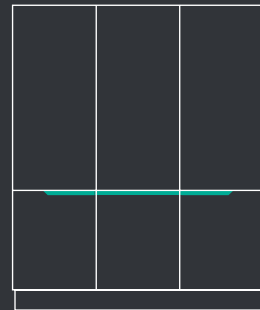
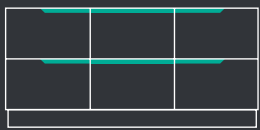

## ESEMPI DI USO DELLE DIVERSE TIPOLOGIE DI APERTURA

EXAMPLES OF USE OF THE DIFFERENT  
OPENING TYPES

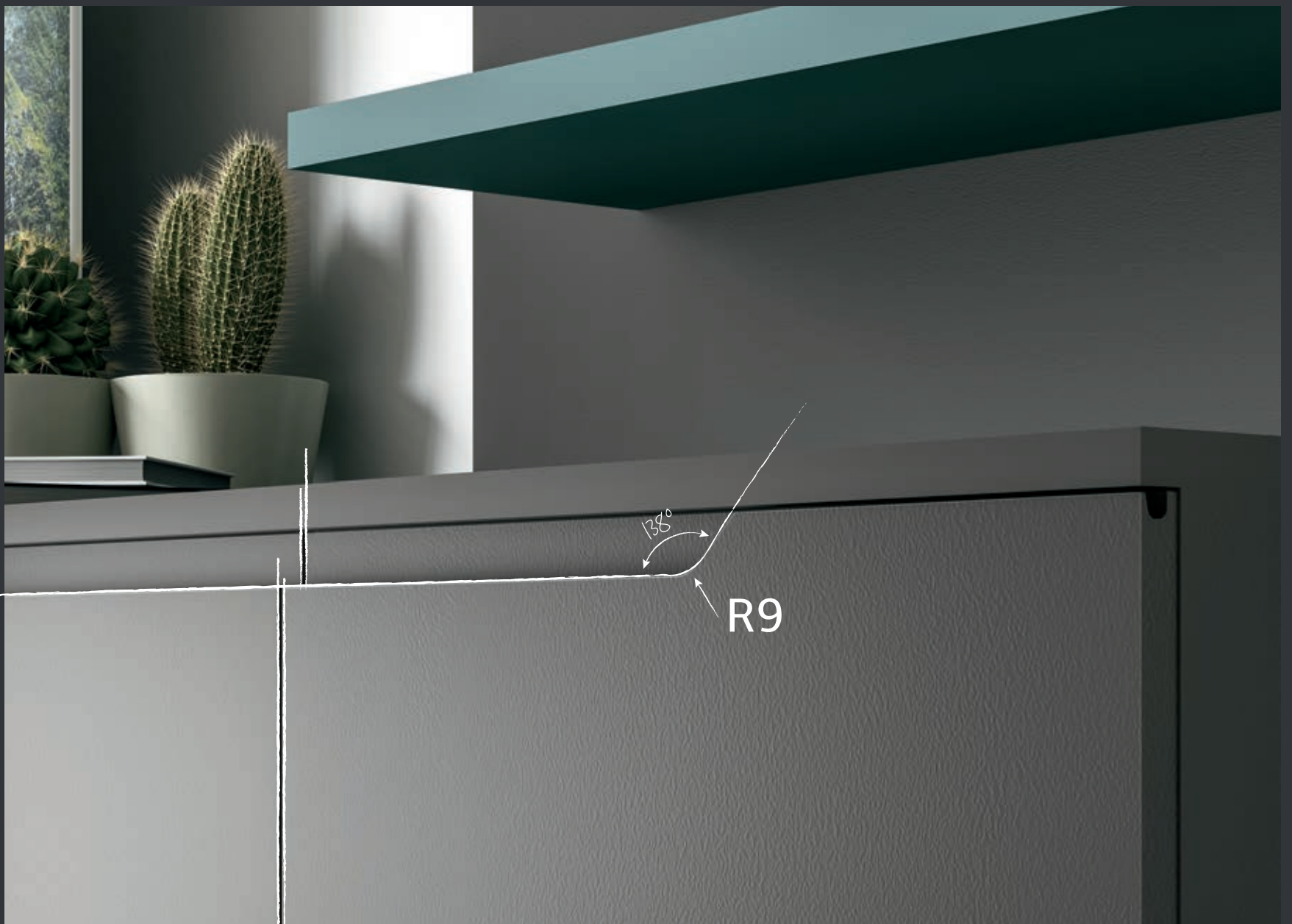



ANTE BASI / COLONNE:  
LACCATO OPACO LINO  
BASE DOORS / COLUMNS:  
LINEN MATT LACQUERED

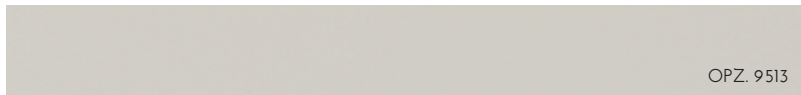

ANTE PENSILI / BANCONE / LIBRERIA:  
IMPIALLACCIATE IN NOCE CANALETTO PORO SEMI APERTO  
WALL UNIT DOORS / COUNTER / BOOKSHELF:  
VENEERED CANALETTO WALNUT SEMI-OPEN PORE



LIBRERIA:  
MELAMINICO OPACO LAVAGNA  
BOOKSHELF:  
SLATE GREY MATT MELAMINE



TOP:  
LAMINATO MARMO NUVOLATO FIN. PLAMKY ABSI  
WORKTOP:  
CLOUDY MARBLE LAMINATE PLAMKY FINISH ABSI



ZOCCOLO:  
ALLUMINIO FINITURA BRILL  
PLINTH:  
ALUMINIUM BRILL FINISH



CUCINA + LIBRERIA  
KITCHEN + BOOKSHELF

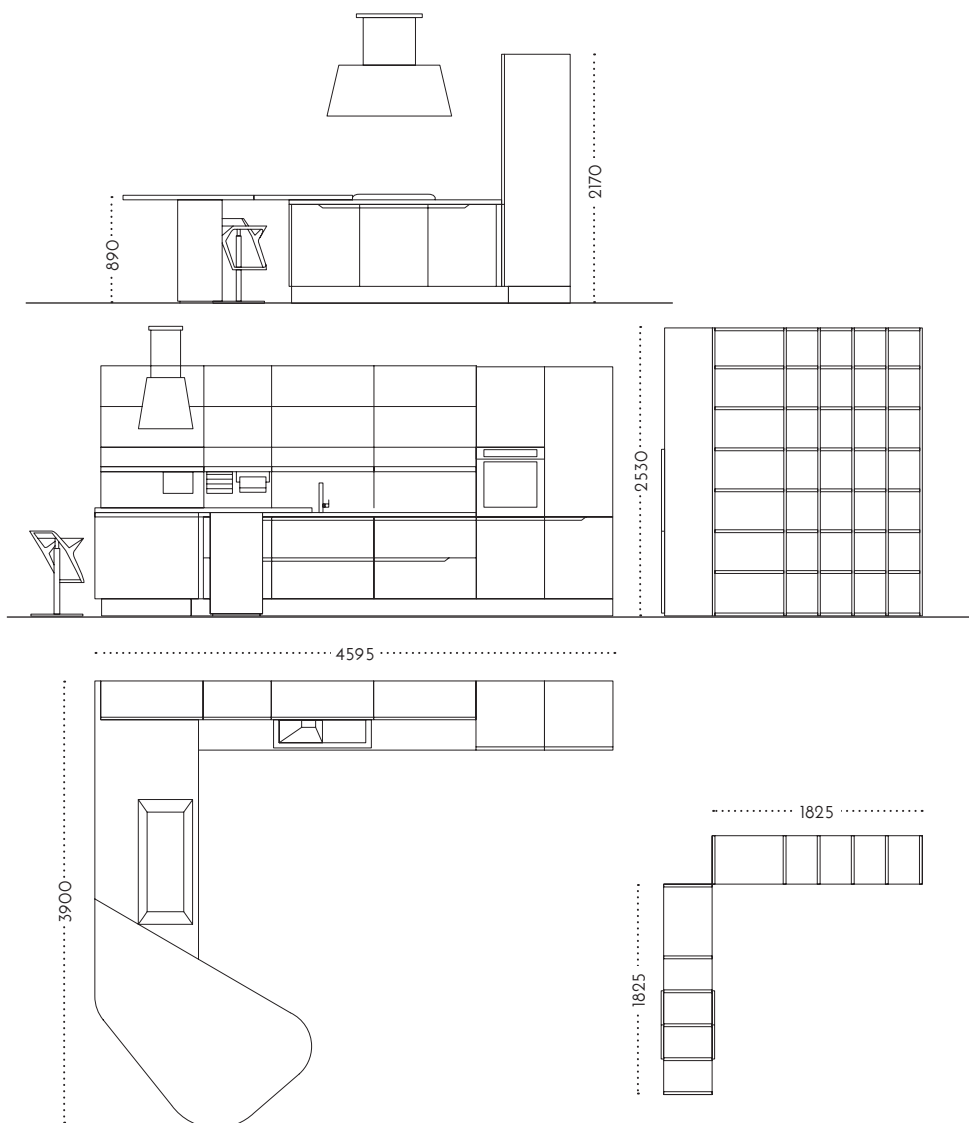

LEND

TAVOLO:  
STRUTTURA IN METALLO NERO,  
PIANO VETRO NERO OPACO  
OPZ. 08  
TABLE:  
BLACK METAL STRUCTURE,  
BLACK MATT GLASS TOP OPZ. 08



KETA

SEDIA:  
STRUTTURA IN  
TECNOPOLIMERO  
GRIGIO GRAFITE OPZ. 21  
CHAIR:  
STRUCTURE GRAPHITE GREY  
TECHNOPOLYMER OPZ. 21



FREED

SGABELLO:  
STRUTTURA SATINATO,  
TELAIO NERO, SEDUTA BIANCO  
OPZ. 1000  
STOOL:  
STRUCTURE WITH SATIN FINISH,  
BLACK FRAME, WHITE SEAT  
OPZ. 1000

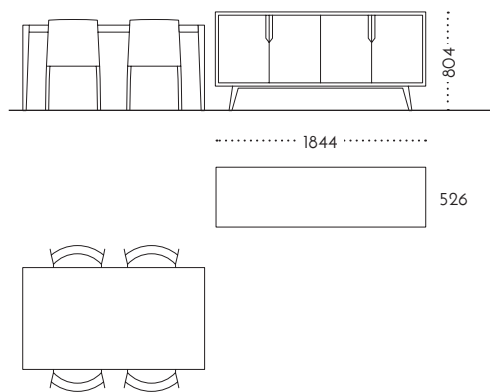

LIVING

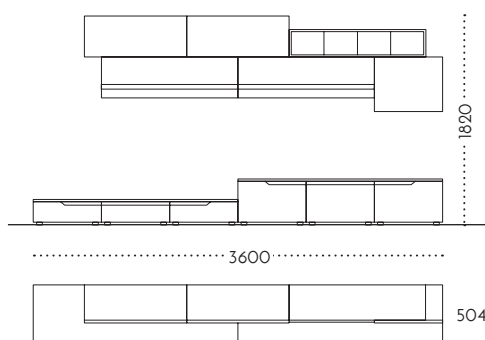



# LUNA02 | ROVERE GRIGIO TRAFFICO + LACCATO GRIGIO TRAFFICO

ANTE BASI / COLONNE:  
 IMPIALLACCIATE IN ROVERE GRIGIO TRAFFICO LACCATE A PORO APERTO  
 + LACCATO OPACO GRIGIO TRAFFICO

BASE DOORS / COLUMNS:  
 VENEERED TRAFFIC GREY OAK OPEN-PORE LACQUERED  
 + TRAFFIC GREY MATT LACQUERED



OPZ. 5431



OPZ. 9511

ANTE PENSILI:  
 LACCATO LUCIDO GRIGIO TRAFFICO

WALL UNIT DOORS:  
 TRAFFIC GREY GLOSSY LACQUERED



OPZ. 9512

SOTTOPENSILI MODULAR:  
 NERO  
 MODULAR UNDER WALL CABINETS  
 BLACK

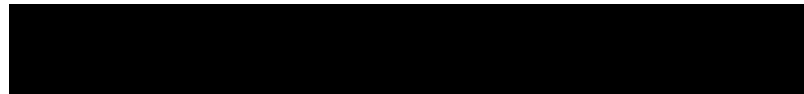

TOP:  
 LAMINATO OLD BLACK FINITURA URBAN ABS1

WORKTOP:  
 OLD BLACK LAMINATE WITH URBAN FINISH ABS1

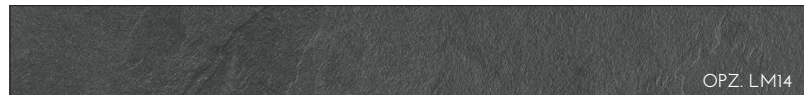

OPZ. LM14

ZOCCOLO:  
 ALLUMINIO FINITURA BRILL

PLINTH:  
 ALUMINIUM BRILL FINISH



OPZ. 412

## JOE

SGABELLO:  
 STRUTTURA METALLO VERNICIATO  
 GRAFITE 084JOGGC ,  
 SEDUTA CUIO RIGENERATO  
 GIALLO OCRA OPZ. Z22

STOOL:  
 GRAPHITE-COATED METAL  
 STRUCTURE 084JOGGC ,  
 REGENERATED LEATHER SEAT IN  
 OCHRE YELLOW OPZ. Z22



## CUCINA KITCHEN

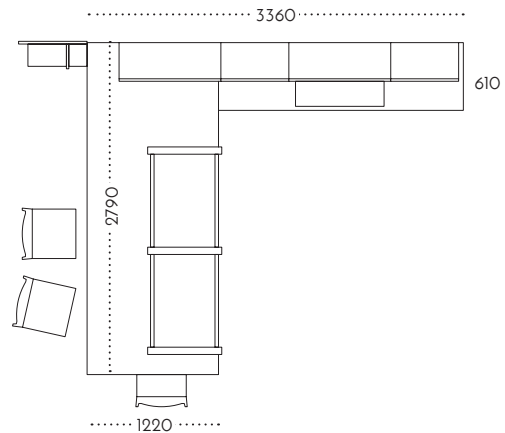
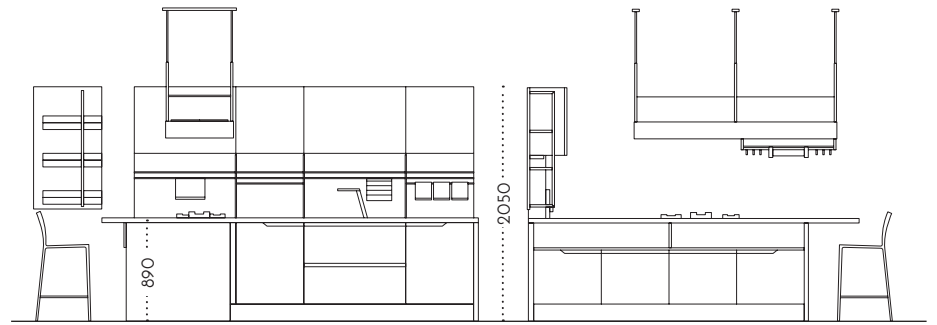

## COLONNE COLUMNS

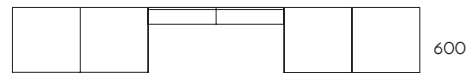
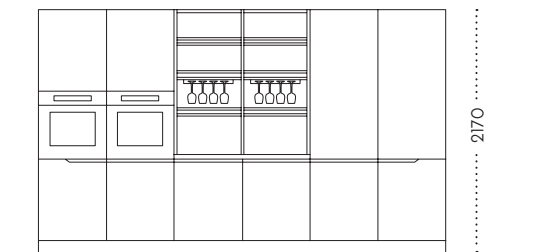

## LIVING

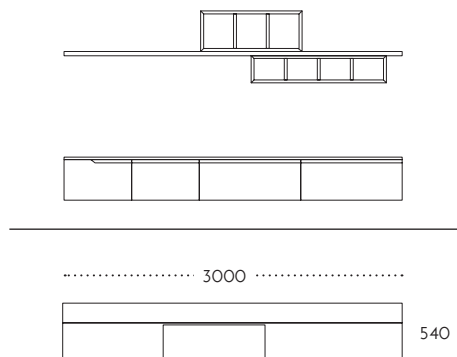



# LUNA03 | ROVERE MORESCO + LACCATO BIANCO ASSOLUTO

ANTE BASI:  
 IMPIALLACCIATE IN ROVERE MORESCO SPAZZOLATE MATERICHE  
 BASE DOORS:  
 VENEERED BRUSHED TEXTURED MOORISH OAK



ANTE COLONNE:  
 LACCATO OPACO BIANCO ASSOLUTO  
 COLUMNS DOORS:  
 ABSOLUTE WHITE MATT LACQUERED



LIBRERIA / ELEMENTI A GIORNO:  
 MELAMINICO BIANCO + LACCATO OPACO FUMO  
 BOOKSHELF / OPEN UNITS:  
 WHITE MELAMINE + SMOKE MATT LACQUERED



LIBRERIA INTERPARETE TOWER HI - LINE:  
 STRUTTURA NERO + MENSOLE VETRO TRASPARENTE  
 TOWER HI-LINE PARTITION BOOKCASE:  
 BLACK STRUCTURE + TRANSPARENT GLASS SHELVES

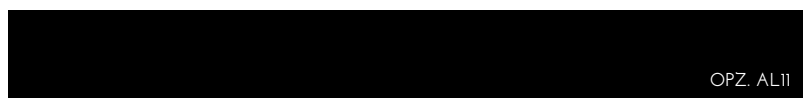

TOP:  
 UNICOLOR BIANCO CALDO OPACO FINITURA SCHIKY U3  
 WORKTOP:  
 UNICOLOR MATT WARM WHITE SCHIKY FINISH U3

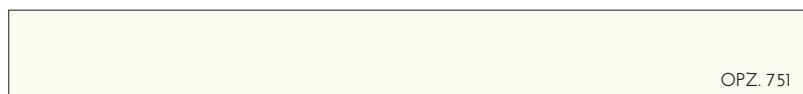

ZOCCOLO:  
 ALLUMINIO FINITURA BRILL  
 PLINTH:  
 ALUMINIUM BRILL FINISH



## POK

TAVOLO:  
 STRUTTURA IN METALLO NERO OPZ. NE,  
 PIANO IMPIALLACCIATO ROVERE MORESCO  
 TABLE:  
 BLACK METAL STRUCTURE OPZ. NE,  
 MOORISH OAK VENEERED TOP



## RIBES

SEDIA:  
 STRUTTURA FRASSINO  
 FINITURA ROVERE  
 MORESCO OPZ. 5433  
 CHAIR:  
 ASH STRUCTURE FINISH  
 MOORISH OAK OPZ.  
 5433



## BETIS

SGABELLO:  
 STRUTTURA METALLO  
 VERNICIATO FUMO  
 OPZ. 9531  
 STOOL:  
 SMOKE-COATED METAL  
 STRUCTURE OPZ. 9531



## CUCINA KITCHEN

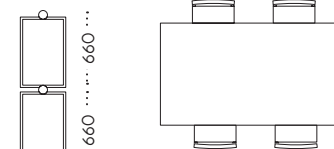
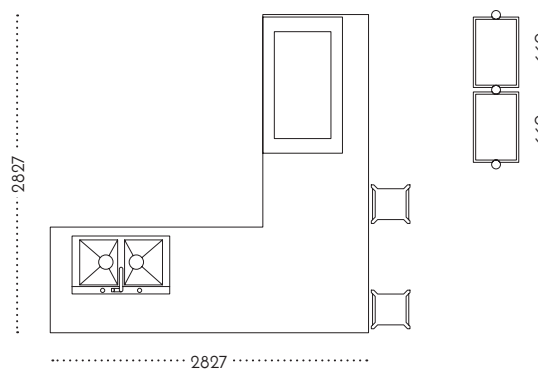
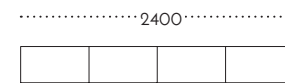
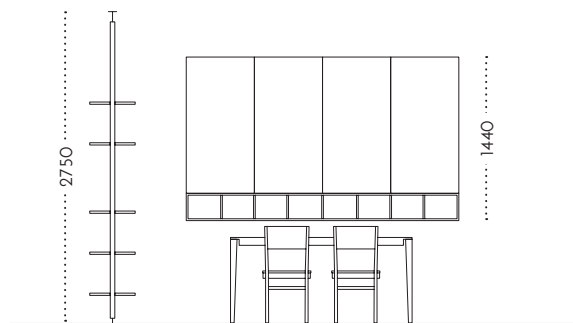
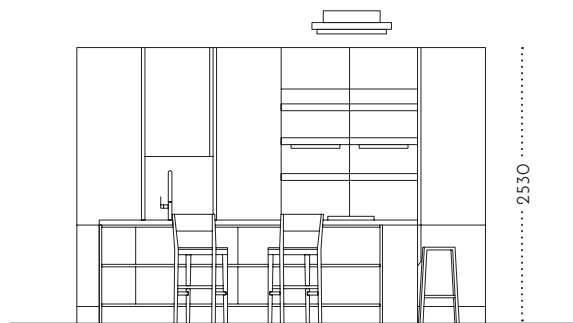
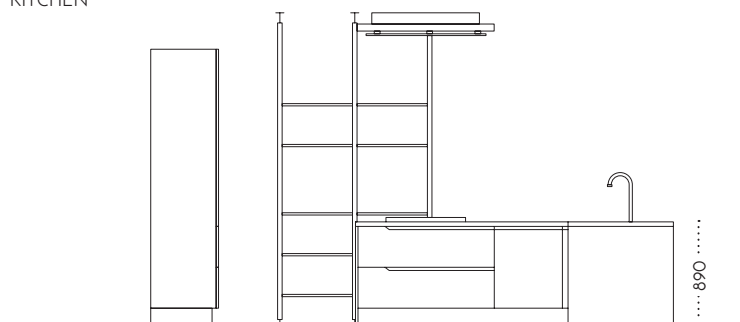

## LIVING

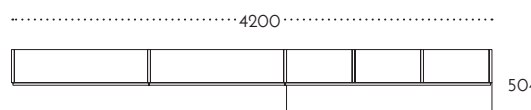
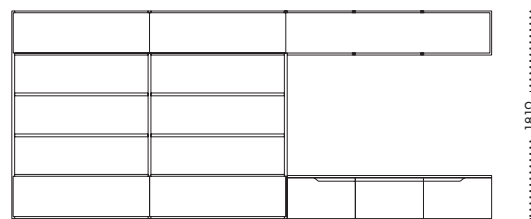



# LUNA04 | NOCE CANALETTO + LACCATO BISTRO

ANTE BASI / COLONNE / ANTE LIVING:  
 IMPIALLACCIATE IN NOCE CANALETTO PORO SEMI APERTO  
 BASE DOORS / COLUMNS / LIVING DOORS:  
 VENEERED CANALETTO WALNUT SEMI-OPEN PORE



ANTE PENSILI / LIVING:  
 LACCATO OPACO BISTRO  
 WALL UNIT DOORS / LIVING:  
 MATT LACQUERED BISTRO



SOTTOPENSILI MODULAR:  
 NERO  
 MODULAR UNDER WALL CABINETS  
 BLACK



TOP:  
 GRES LAMINAM NERO BLEND  
 WORKTOP:  
 GRES LAMINAM BLACK BLEND



ZOCCOLO:  
 BISTRO  
 PLINTH:  
 BISTRO



CUCINA  
 KITCHEN

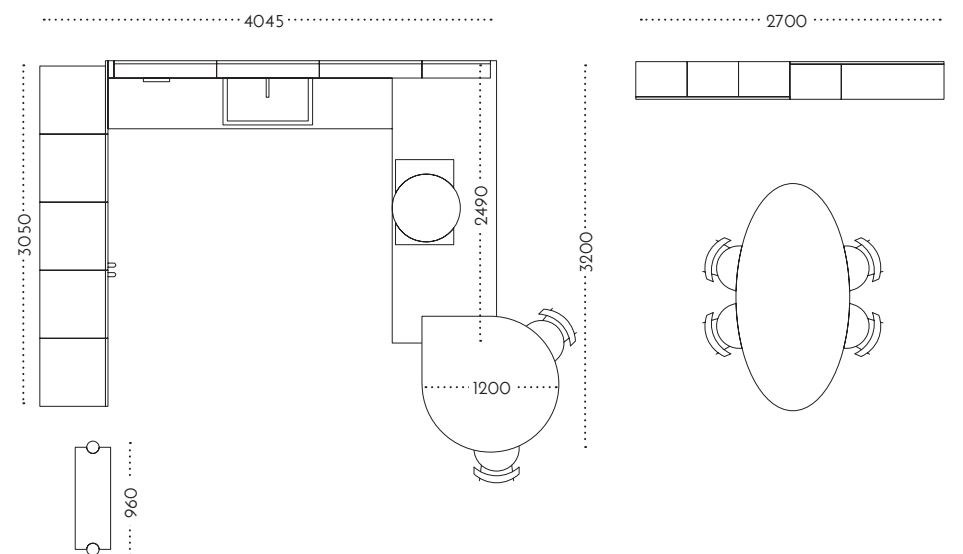
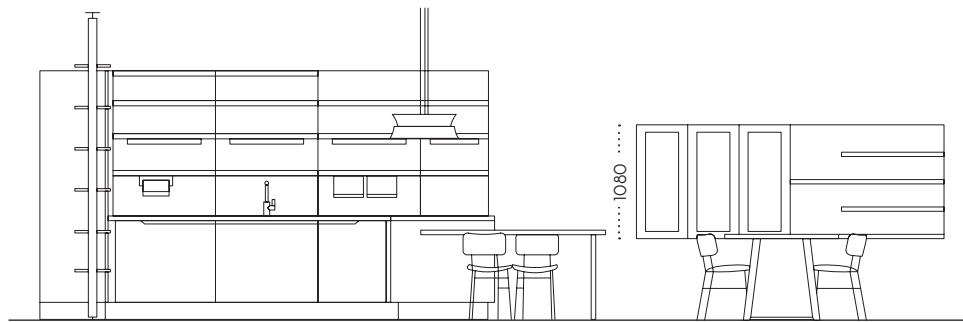
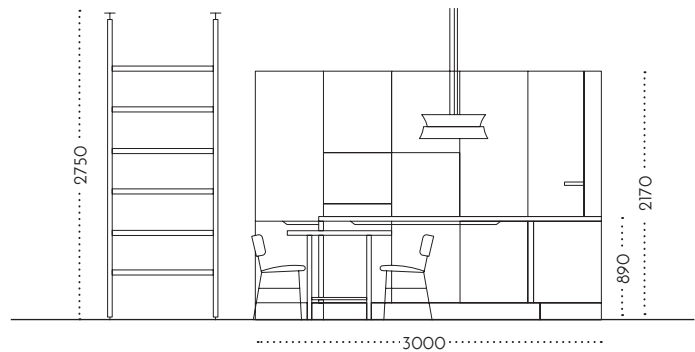

## POK OVAL

TAVOLO:  
 STRUTTURA IN METALLO NERO OPZ. 08  
 PIANO IMPIALLACCIATO NOCE  
 CANALETTO

TABLE:  
 BLACK METAL STRUCTURE OPZ.08,  
 CANALETTO WALNUT VENEERED TOP



## MASTER

SEDIA  
 STRUTTURA IN METALLO ORO ROSA,  
 SEDUTA LAMINATO FENIX NERO  
 (OPZ. HF720) CODICE 084MTDOF

CHAIR  
 PINK GOLD METAL STRUCTURE,  
 BLACK FENIX LAMINATE SEAT  
 (OPZ. HF720) CODE 084MTDOF



LIVING

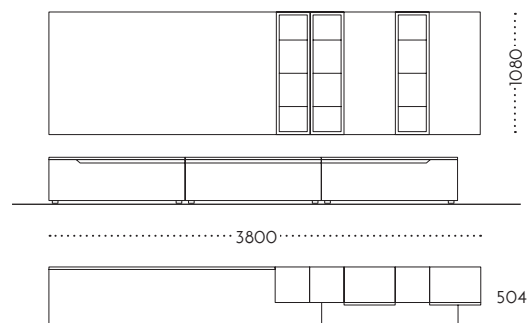



ANTE BASI / COLONNE / LIVING:

IMPIALLACCIATE IN ROVERE CARBON LACCATI A PORO APERTO  
+ LACCATO BIANCO ASSOLUTO OPACO

BASE DOORS / COLUMNS / LIVING:

VENEERED CARBON OAK OPEN-PORE LACQUERED  
+ MATT LACQUERED ABSOLUTE WHITE



PENSILI A GIORNO IMPIALLACCIATI:

IMPIALLACCIATI IN ROVERE CARBON LACCATE A PORO APERTO

VENEERED OPEN WALL UNIT:

VENEERED CARBON OAK OPEN-PORE LACQUERED



MENSOLE / SCHIENALI SHELF:

LACCATO BIANCO OPACO

SHELVES / SHELF PANELS:

MATT LACQUERED WHITE



TOP:

QUARZO VEGA LUCIDO

WORKTOP:

QUARZO POLISHED VEGA



ZOCCOLO:

ALLUMINIO FINITURA BISTRO

PLINTH:

ALUMINIUM BISTRO FINISH



MINOX

TAVOLO:

STRUTTURA IN METALLO NERO  
OPZ. NE, PIANO FENIX NERO  
OPZ. 0720

TABLE:

BLACK METAL STRUCTURE  
OPZ. NE, BLACK FENIX TOP  
OPZ. 0720



KETA

SEDIA:

STRUTTURA IN  
TECNOPLIMERO  
BLU AVIO OPZ.98

CHAIR:

STRUCTURE  
AVIATION BLUE  
TECHNOPOLYMER OPZ.98



CUCINA

KITCHEN

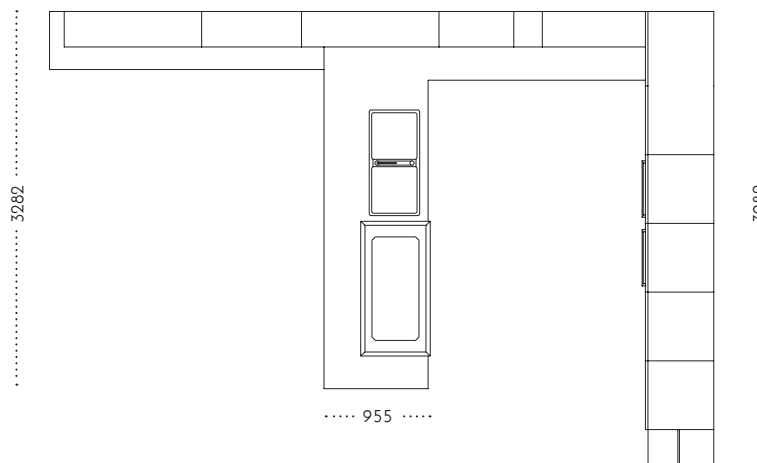
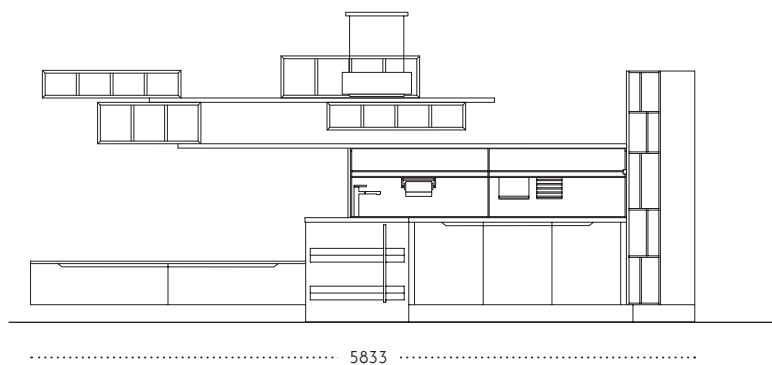
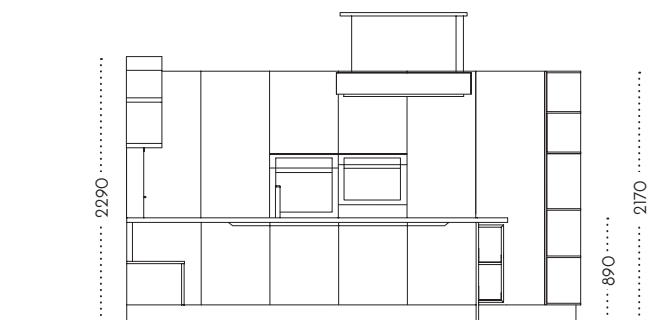

LIVING

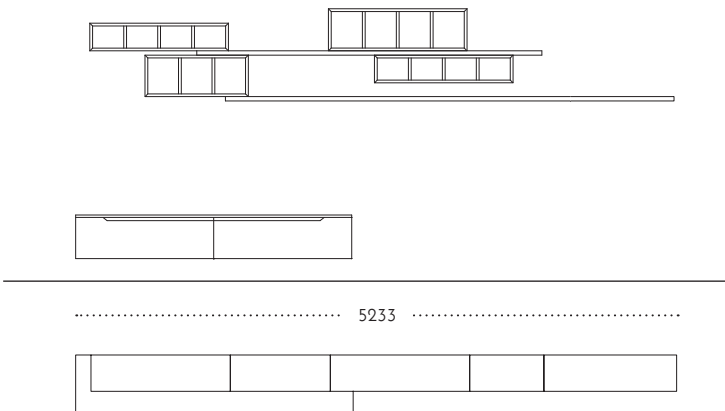



# LUNA06 | ROVERE LINO + LACCATO LINO

ANTE BASI / COLONNE / ANTE LIBRERIA:  
 IMPIALLACCIATE IN ROVERE LINO SPAZZOLATE MATERICHE  
 BASE DOORS / COLUMNS / BOOKSHELF DOORS:  
 VENEERED BRUSHED TEXTURED LINEN OAK



ANTE PENSILI:  
 LACCATO LINO OPACO  
 WALL UNIT DOORS:  
 MATT LACQUERED LINEN

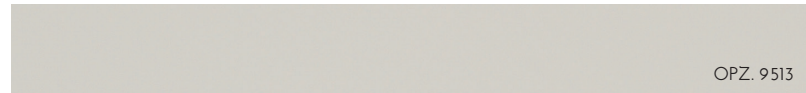

LIBRERIA:  
 ANTE IMPIALLACCIATE IN ROVERE LINO SPAZZOLATE MATERICHE  
 + BIANCO E ROSSO TOSCANO  
 BOOKCASE:  
 VENEERED BRUSHED TEXTURED LINEN OAK DOORS  
 + WHITE AND TUSCAN RED



TOP:  
 UNICOLOR TOBACO OPACO FINITURA PLAMKY U3  
 WORKTOP:  
 UNICOLOR MATT TOBACO WITH PLAMKY FINISH U3



ZOCCOLO:  
 ALLUMINIO FINITURA BRILL  
 PLINTH:  
 ALUMINIUM BRILL FINISH



## SPIN

TAVOLO:  
 STRUTTURA IN METALLO RUGGINE OPZ. RU  
 PIANO IMPIALLACCIATO ROVERE MORESCO  
 TABLE:  
 RUST OPZ. RU METAL STRUCTURE,  
 MOORISH OAK VENEERED TOP



## NENÈ

SEDIA:  
 STRUTTURA IN POLIPROPILENE  
 CORDA 084NNDC, SEDUTA CUIO  
 RIGENERATO CASTORO OPZ. Z53  
 CHAIR:  
 JUTE POLYPROPYLENE STRUCTURE  
 084NNDC, BEAVER REGENERATED  
 LEATHER SEAT OPZ. Z53



## CUCINA KITCHEN

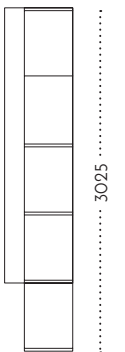
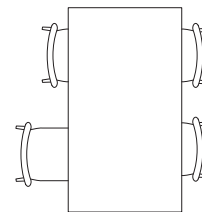
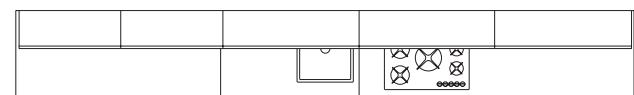
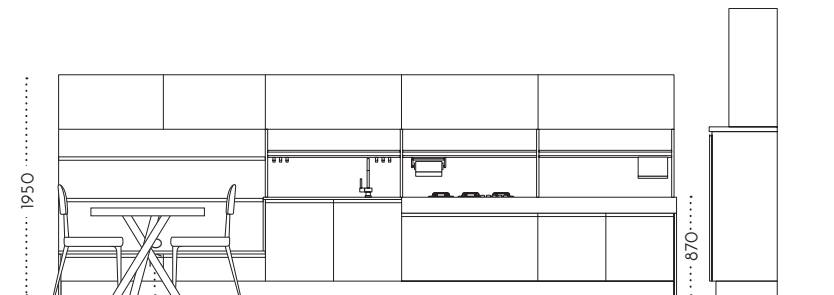
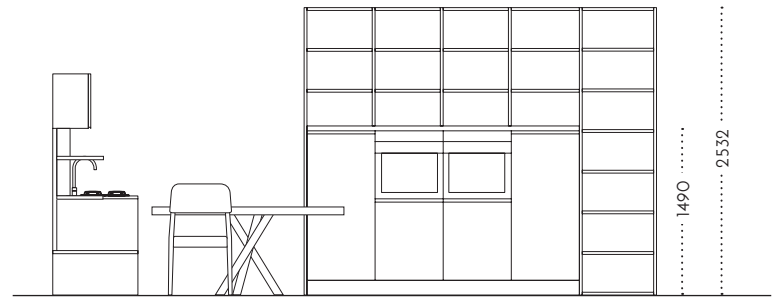

## LIVING / MADIA LIVING / SIDEBBOARD

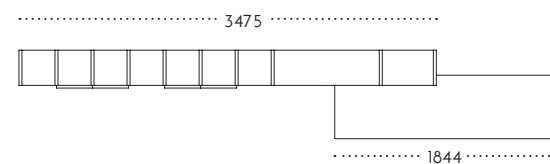
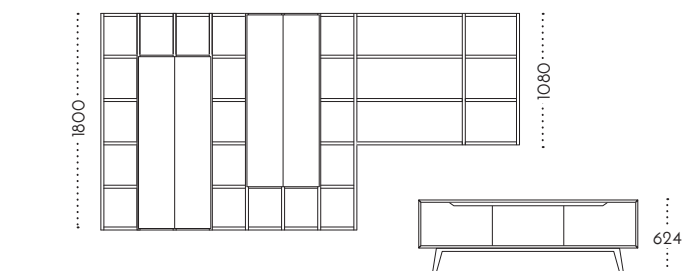



## LUNA 07 | ROVERE BIANCO + LACCATO GRIGIO PIOMBO

## ANTE BASI / COLONNE:

IMPIALLACCIATE IN ROVERE BIANCO LACCATE A PORO APERTO

## BASE DOORS / COLUMNS:

VENEERED WHITE OAK OPEN-PORE LACQUERED



OPZ. 5429

## ANTE PENSILI / BOISERIE LIVING:

LACCATO OPACO GRIGIO PIOMBO

+ ANTE LIVING LACCATE MALTA CON FONDO CEMENTO PIOMBO

## WALL UNIT DOORS / BOISERIE LIVING:

MATT LEAD GREY LACQUERED

+ LIVING AREA DOORS, LACQUERED MORTAR FINISH WITH LEAD CEMENT BASE



OPZ. 9537



OPZ. LM25

## MENSOLE LIVING:

LACCATO OPACO VERDE POSITANO

## LIVING SHELVES:

POSITAN GREEN MATT LACQUERED



OPZ. 8471

## LIBRERIA INTEGRATA PENSILI CUCINA:

BIANCO

BOOKCASE INTEGRATED INTO THE KITCHEN WALL UNITS:

WHITE



## TOP:

LAMINATO FENIX VERDE COMMODORO

## WORKTOP:

COMMODORO GREEN FENIX LAMINATE



OPZ. 0750

## ZOCCOLO:

ALLUMINIO FINITURA BRILL

## PLINTH:

ALUMINIUM BRILL FINISH



OPZ. 412

## NIEM

## SGABELLO:

STRUTTURA CROMO

SCOCCA BICOLORE

BIANCO/NERO OPZ. 0010

## STOOL:

2-COLOUR WHITE/BLACK

STRUCTURE CHROME FRAME

OPZ. 0010



## CUCINA

## KITCHEN

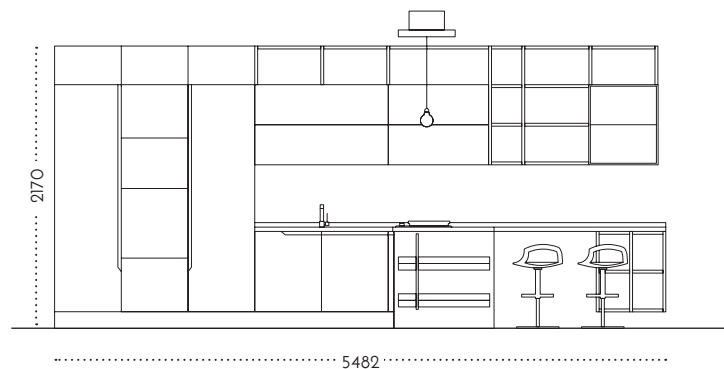
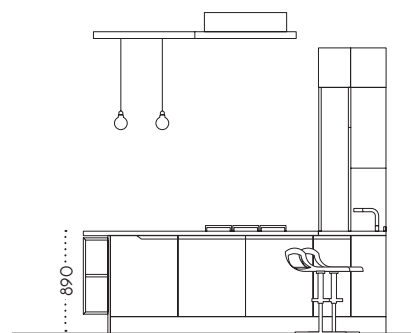

5482

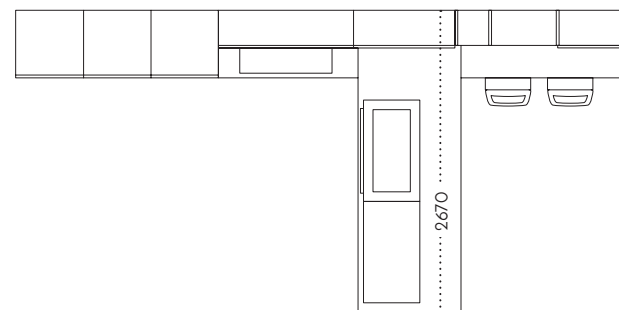

## LIVING

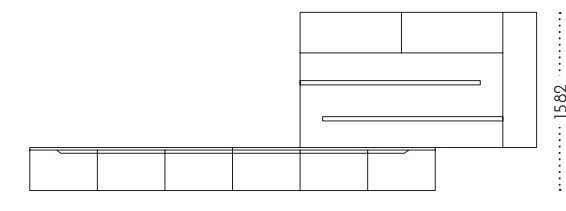

4500

504

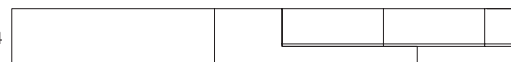



# LUNA08 | ROVERE NATUR + LACCATO BIANCO ASSOLUTO

ANTE COLONNE:  
LACCATO LUCIDO BIANCO ASSOLUTO  
COLUMNS DOORS:  
ABSOLUTE WHITE GLOSSY LACQUERED

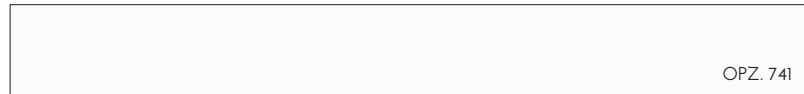

ANTE BASI:  
IMPIALLACCIATE IN ROVERE NATUR SPAZZOLATE MATERICHE  
BASE DOORS:  
VENEERED BRUSHED TEXTURED NATUR OAK



ANTA LIVING:  
LACCATE MALTA CON FONDO CEMENTO BIANCO  
LIVING DOOR:  
WHITE LACQUERED MORTAR WITH CEMENT SURFACE



MOBILI A GIORNO / LIBRERIA:  
MELAMINICO BIANCO  
OPEN WALL UNITS / BOOKCASE:  
WHITE MELAMINE



TOP:  
UNICOLOR BIANCO CALDO OPACO U3  
WORKTOP:  
MATT WARM WHITE UNICOLOR U3

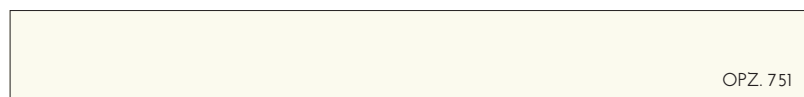

ZOCCOLO:  
ALLUMINIO FINITURA BRILL  
PLINTH:  
ALUMINIUM BRILL FINISH



## SLIM

SEDIA:  
STRUTTURA METALLO VERNICIATO  
NERO 084SMDN, RIVESTIMENTO  
CUOIO BLU OCEANO OPZ. U67

CHAIR:  
BLACK PAINTED METAL STRUCTURE  
084SMDN, LEATHER SEAT IN  
OCEAN BLUE OPZ. U67



SGABELLO:  
STRUTTURA METALLO VERNICIATO  
BIANCO 084SMGB,  
SEDUTA CUOIO BIANCO OPZ. U05

STOOL:  
WHITE PAINTED METAL STRUCTURE 084SMGB,  
LEATHER SEAT WHITE OPZ. U05

CUCINA + LIVING  
KITCHEN + LIVING

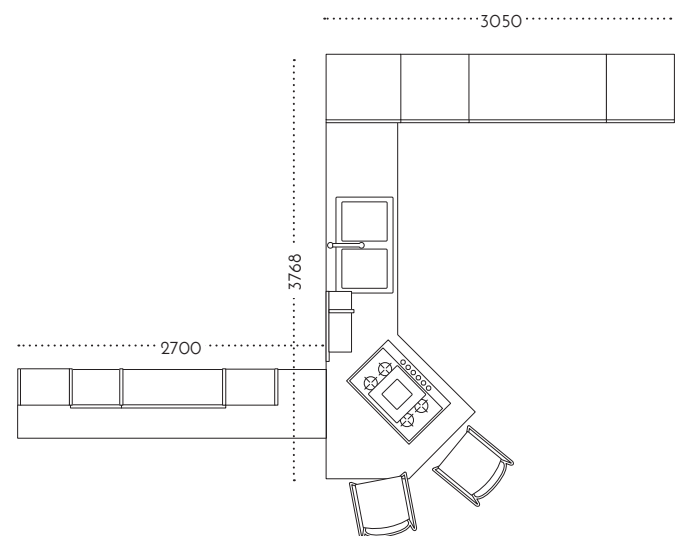
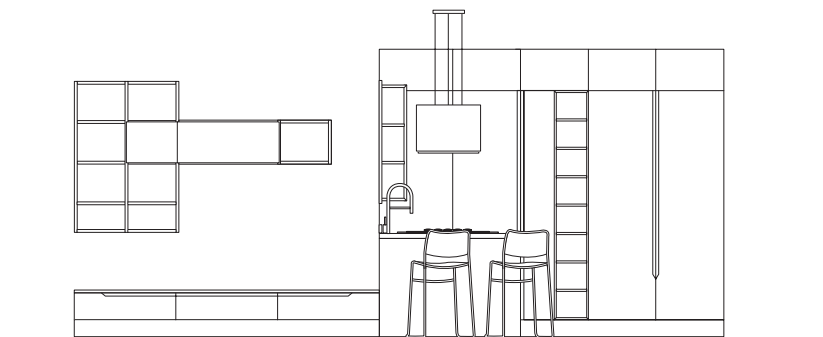
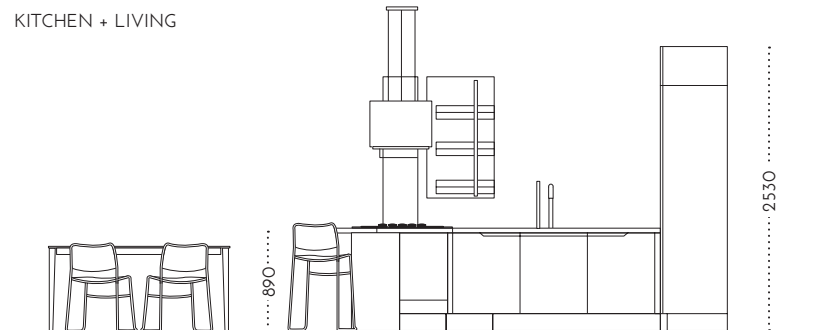

LIBRERIA / MADIA  
BOOKCASE / SIDEBORD

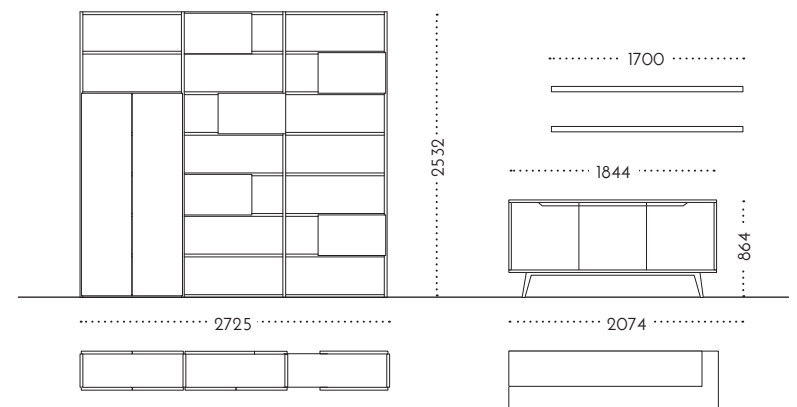



## ANTE BASI / COLONNE:

IMPIALLACCIATE IN ROVERE MORESCO SPAZZOLATE MATERICHE  
+ LACCATO OPACO FUMO

## BASE DOORS / COLUMNS:

VENEERED BRUSHED TEXTURED MOORISH OAK  
+ SMOKE MATT LACQUERED



## LIBRERIA INTERPARETE TOWER HI - LINE:

STRUTTURA NERO E MENSOLE VETRO FUMO'

TOWER HI-LINE PARTITION BOOKCASE:  
BLACK STRUCTURE AND SMOKED GLASS SHELVES

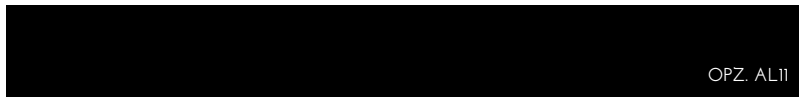

## TOP:

UNICOLOR H4 CARNICO FINITURA PLAMKY U3

## WORKTOP:

UNICOLOR H4 CARNICO FINITURA PLAMKY U3



## ZOCZOLO:

ALLUMINIO VERNIVIATO A POLVERE OPACO FUMO

## PLINTH:

ALUMINIUM SMOKE POWDER COATED MATT FINISH



## INCLINE

## TAVOLO:

STRUTTURA IN METALLO  
FERRO GREZZO OPZ. FG,  
PIANO IMPIALLACCIATO  
ROVERE MORESCO

## TABLE:

ROUGH IRON METAL STRUCTURE OPZ. FG,  
MOORISH OAK VENEERED TOP



## JOE

## SEDIA E SGABELLO:

STRUTTURA METALLO VERNICIATO GRAFITE  
SEDIA - 084JODGC / SGABELLO - 084JOGGC,  
SEDUTA CUIOIO RIGENERATO  
GRIGIO KENIA OPZ. Z18

## CHAIR AND STOOL:

GRAPHITE-COATED METAL STRUCTURE  
CHAIR - 084JODGC / STOOL - 084JOGGC,  
REGENERATED LEATHER SEAT  
KENYA GREY OPZ. Z18



## CUCINA

## KITCHEN

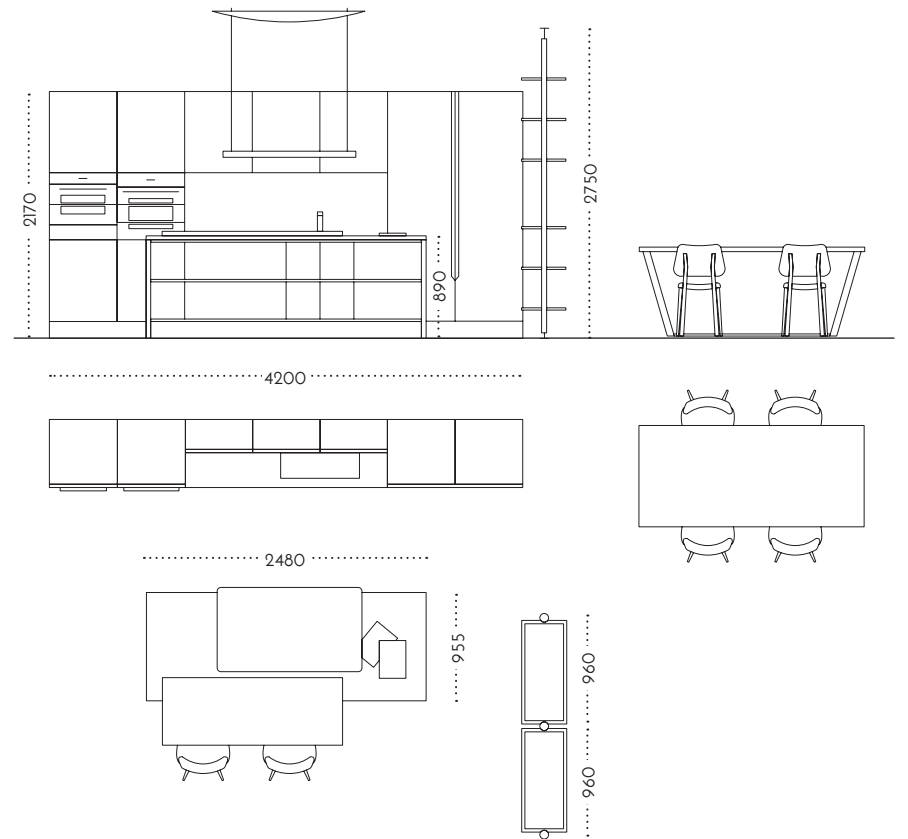

## LIVING / MADIA

## LIVING / SIDEBBOARD

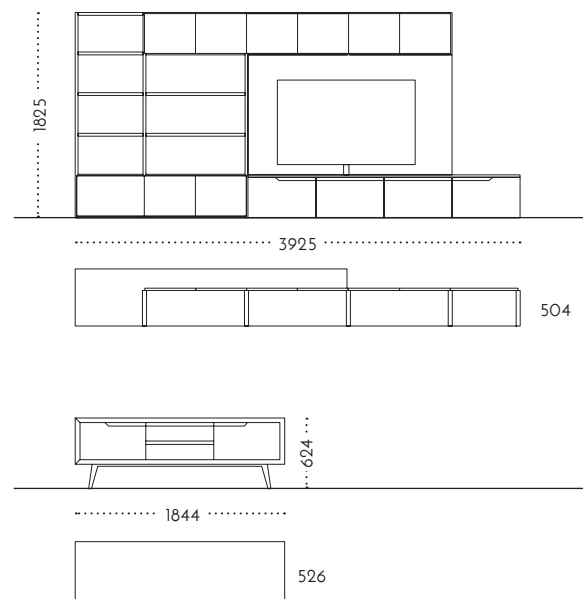



# LUNA10 | ROVERE GRIGIO NATURALE + LACCATO CENERE

ANTE BASI / ANTE PENSILI / LIVING:  
 IMPIALLACCIATE IN ROVERE GRIGIO REALE LACCATE A PORO APERTO  
 BASE DOORS / WALL UNIT DOORS / LIVING:  
 VENEERED ROYAL GREY OAK OPEN-PORE LACQUERED



COLONNE / PENSILI LIVING:  
 LACCATO OPACO CENERE  
 COLUMNS / LIVING WALL UNIT DOORS:  
 ASH MATT LACQUERED



SCHIENALI MAGNETOLAB:  
 VETRO LUMINOSO A LED BIANCO CALDO  
 MAGNETOLAB PANEL:  
 WARM WHITE LED-LIT GLASS



LIBRERIA INTERPARETE VERTICAL LINE:  
 MENSOLE IMPIALLACCIATE IN ROVERE GRIGIO REALE LACCATE A PORO APERTO  
 + STRITTURA NERO  
 VERTICAL LINE PARTITION BOOKCASE:  
 VENEERED ROYAL GREY OAK OPEN-PORE LACQUERED SHELVES  
 + BLACK STRUCTURE



PIANO SNACK:  
 LAMINATO ROVERE MENPHIS FINITURA ALEVÈ  
 SNACK BAR:  
 MENPHIS OAK LAMINATE ALEVÈ FINISH



TOP:  
 LAMINATO CEMENTO FINITURA PLAMKY ABS 1  
 WORKTOP:  
 CEMENT LAMINATE WITH PLAMKY FINISH ABS 1



ZOCCOLO:  
 ALLUMINIO FINITURA BRILL  
 PLINTH:  
 ALUMINIUM BRILL FINISH



## LEND

TAVOLO:  
 STRUTTURA IN METALLO BIANCO,  
 PIANO VETRO BIANCO OPACO OPZ. 06  
 TABLE:  
 WHITE METAL STRUCTURE,  
 WHITE MATT GLASS TOP OPZ. 06



## CUCINA KITCHEN

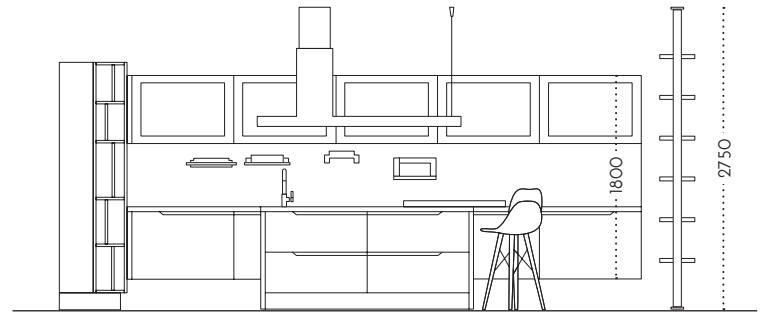
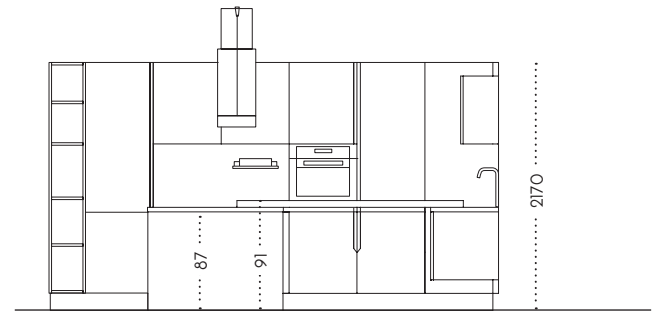

5150

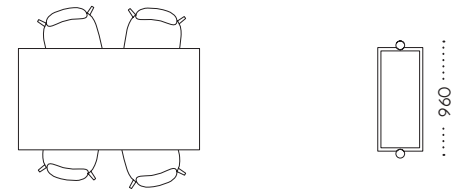
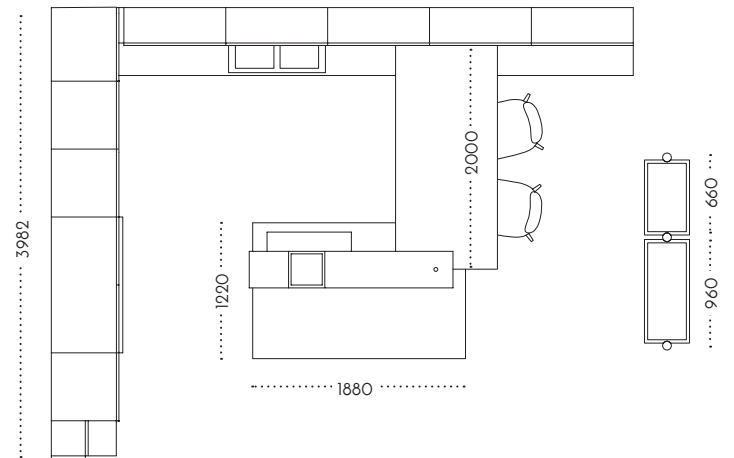

## LIVING / MADIA LIVING / SIDEBBOARD

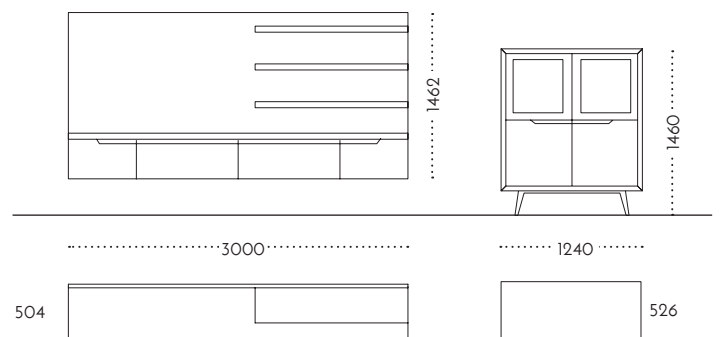

## EBUL

SEDIA E SGABELLO:  
 SCOCCA BIANCO OPZ. 050BIA,  
 GAMBE FAGGIO TINTO  
 NATURALE 084EBD / 084EBG  
 CHAIR AND STOOL:  
 WHITE SEAT OPZ. 050BIA,  
 LEG NATURAL STAINED  
 BEECH 084EBD / 084EBG





PROGETTO E COORDINAMENTO  
UFFICIO R&S  
UFFICIO MKT  
'LUBE SERVICE & ENGINEERING S.R.L.'  
STUDIO FERRIANI

GRAFICA  
STUDIO FERRIANI

DIGITAL PHOTOGRAPHY  
STUDIO FERRIANI

STAMPA  
GRAFICHE ANTIGA



PRINTED  
SETTEMBRE 2018

LUBE INDUSTRIES SRL  
VIA DELL'INDUSTRIA, 4  
62010 TREIA (MC) ITALIA  
TEL. CENTRALINO 0733 8401 (R.A.)  
FAX. 0733 840222 - 0733 840333  
INFO@CUCINELUBE.IT  
WWW.CUCINELUBE.IT

LUBE INDUSTRIES SRL SI RISERVA LA FACOLTA' DI APPORTARE IN OGNI MOMENTO E  
SENZA PREAVVISO QUALSIASI MODIFICA TECNICA E CROMATICA RITENUTE UTILI AL  
MIGLIORAMENTO DEI PROPRI PRODOTTI.

I CAMPIONI E I COLORI RIPRODOTTI SONO PURAMENTE INDICATIVI.

LA RAPPRESENTAZIONE IN STAMPA PUO' ALTERARE LE TONALITA' DEI COLORI.

LUBE INDUSTRIES SRL RESERVES THE RIGHT TO MAKE AT ANY TIME AND WITHOUT PRIOR NOTICE ANY  
TECHNICAL AND COLOUR MODIFICATION DEEMED USEFUL FOR THE IMPROVEMENT OF ITS PRODUCTS.  
THE SHOWN SAMPLES AND COLOURS ARE PURELY INDICATIVE.  
PRINTED REPRESENTATION MAY ALTER THE ACTUAL COLOUR TONES.